

1979-1993 Mustang Caster Camber Plate Installation Diagram

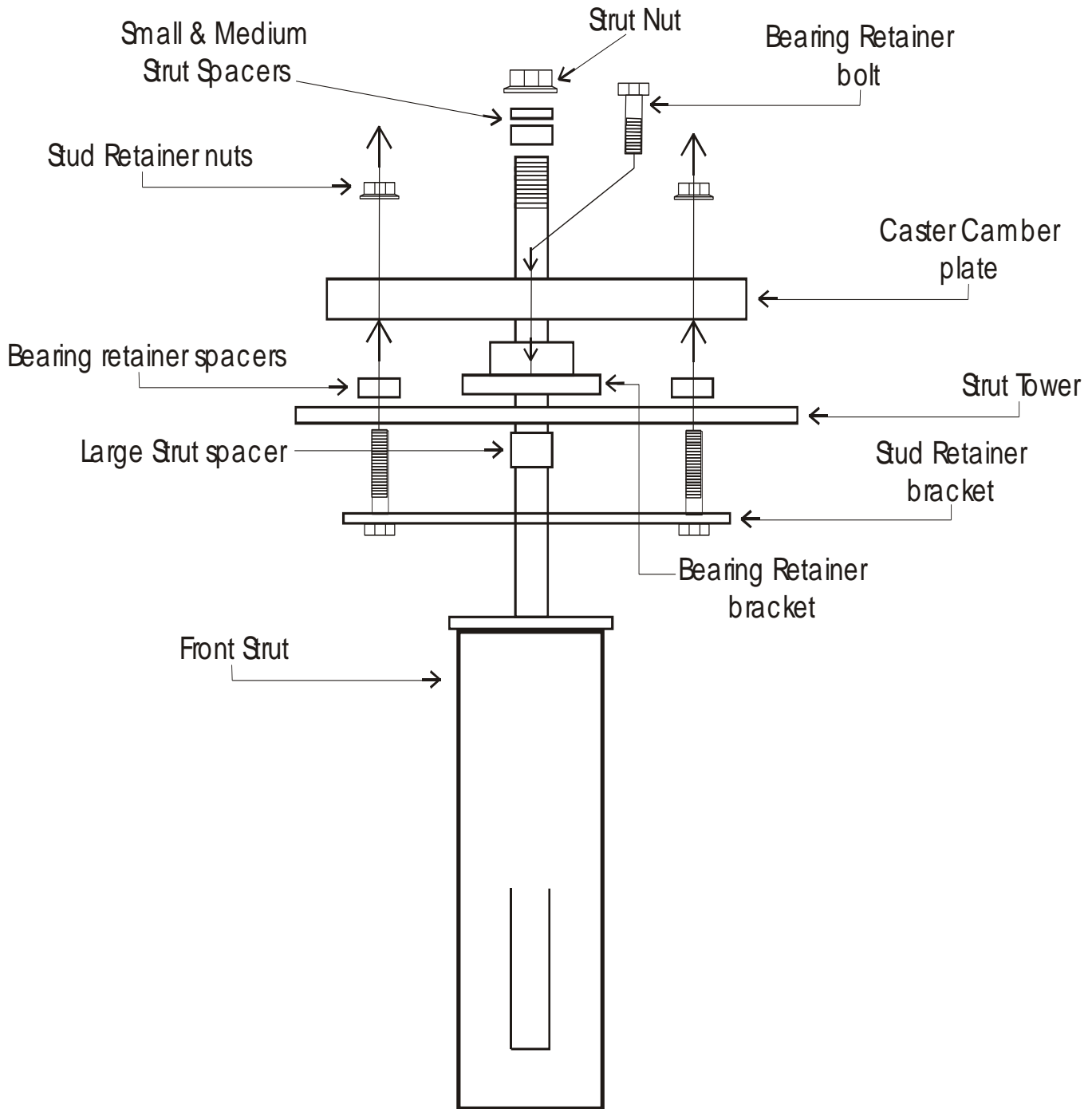



Assembly & Installation Instructions:

1. Lift vehicle front, position jack stands and remove front wheels. Jack one front control arm up to take the weight off it.
2. Unfasten nut on strut top and remove along with washer and bushing. Remove nuts holding factory strut plate. Drill out any rivet in holding plate.
3. Lower jack until you can remove the lower strut bracket, also compressing the strut at the same time. BE CAREFUL NOT TO LOWER THE JACK TOO FAR OR THE SPRING MAY POP OUT AND CAUSE INJURY OR DEATH!!!
4. Slide spacer bushings over the strut shaft with tapered end facing up. Install the lower plate (with studs) from inside the wheel well. Align the studs with the stock holes in the shock tower. Then install the stud spacers on to keep the bearing plate adjustable. Then place the top plate over the studs and fasten it down with the 7/16 flange nuts provided. Do not tighten yet!
5. Raise the jack while aligning the strut shaft with the bearing in the upper plate until the shaft protrudes all the way through. Install the upper bushing and spacer, if necessary, make sure there are adequate threads showing for the strut nut. Install the strut nut and tighten to at least 60 ft/lbs. Tighten the 7/16 flange nuts and 3/8 bolts. Do not over tighten!
6. Lower jack and repeat same operation on the other side. Install wheels, lower car and have car aligned. After alignment, final tighten the 7/16 flange nuts to 50 ft/lbs. And the 3/8 bolts to 22 ft/lbs. Be careful not to over tighten the 3/8 bolts!
7. UPR recommends that you align to factory specs.